

Donaldson offers a wide variety of solutions to reduce your energy costs, improve your productivity, guarantee production quality and help preserve the environment.

## Products

- Activated carbon filters
- Adsorption dryers
- Breathing-air units
- Condensate drains
- Cyclone separators
- Elements
- Filter housing
- High-pressure filters
- Medical vacuum filters
- Membrane dryers
- Micro filters
- Oil/vapour absorbers
- Oil/water separators
- Pre-filters
- Process filter elements
- Process filter housing
- Refrigeration compressed air dryers

- Silicon-free filters
- Steam filters
- Sterile filters
- Sub-micro filters
- Vacuum filters
- Vent filters



# Ultra Filter DF 0035 - DF 1100

### The intelligent overall concept of the filter unites the following characteristics:

- High performance • Efficiency • Compactness
- Easy of use • Flexibility • Safety.

Validated performance data acc. to ISO 12500-1 for reliable achievement of compressed air quality suitable to the application acc. to ISO 8573-1.

Besides energy cost savings by the filter design, the use of the Economiser offers further saving achievements through timely replacement of the used filter elements. The most cost-effective replacement time for the filter element is calculated and LEDs then signal that the "filter exchange" is necessary.

With 9 sizes the Ultra-Filter covers the performance range from 35 to 1100 m<sup>3</sup>/h flow rate and hence conventional compressor capacities between 2 and 120 KW.

### Three versions are available:

**Standard:** With float condensate drain and Economiser.

**Plus:** With float condensate drain and Economiser.

**Superplus:** With level controlled condensate drain UFM-T and Economiser.

A selection of appropriate filter grades by filter element types S, M, V, B, P, A ensure that the right product for the filtration task is always available to the user.

The filter housing design allows an easy replacement of the filter element. The filter bowl is rotated slightly via a bayonet lock and can be removed together with the filter element.

For this a installation height of only a few centimetres of ground clearance is necessary.

Features:	Benefits:	Options	
Validated performance data acc. to ISO 12500-1.	Reliable achievement of compressed air quality acc. to ISO 8573-1.	Econometer	Mechanical differential pressure indicator
Intelligent overall concept.	Flow range, filtration grades, efficiencies and available options perfectly meet requirements of industrial air purification.	Economiser	Differential pressure indicator for the determination of the most economical time for replacement of the filter element; Possibility of remote data transmission
Flow-optimised filter housing and filter element design.	Low pressure losses, thereby saving of energy costs.	KA 1/2 / UFM-P	Float drain, pneumatically
Bayonet fixing between filter head and filter bowl; element can be removed together with filter bowl; filter head with integrated differential pressure indicator can be rotated.	Easy to use construction - simplified filter replacement; simple installation and assembly.	UFM-T	Electronic level-controlled condensate drain without compressed air losses
Minimal installation height for the filter element exchange, differential pressure indicator integrated in filter head.	Compact, space-saving construction - installation within smallest space possible.	UFZ	Time-controlled condensate drain
Changing the coding clip inside the filter cover allows the filter element to be rotated and thus change the flow direction.	High flexibility - filters can be either used as coalescing filters or particulate filters.	S	Plug
Filter cannot be opened under pressure due to bayonet lock.	High safety during operation.	Wall bracket	Distance to the wall is adjustable (except DF-0035)
Filter housings immersion-lacquered on the inside and outside surface.	Ensures long-term corrosion protection, in particular against aggressive condensates.	Connection adapter	Intelligent adapter solution for filter combination
		Filter elements	V/M/S (coalescing filter) P/B (Pre-filter/particulate filter) A (activated carbon filter)

Pos.	Pieces	Description
1	1	Filter head
2	1	Lower housing bowl
3	2	Wall bracket (option)
4	1	Econometer
5 DF 0035 - DF 0750	1	Internal automatic drain KA 1/2
6 DF 1100	1	External automatic

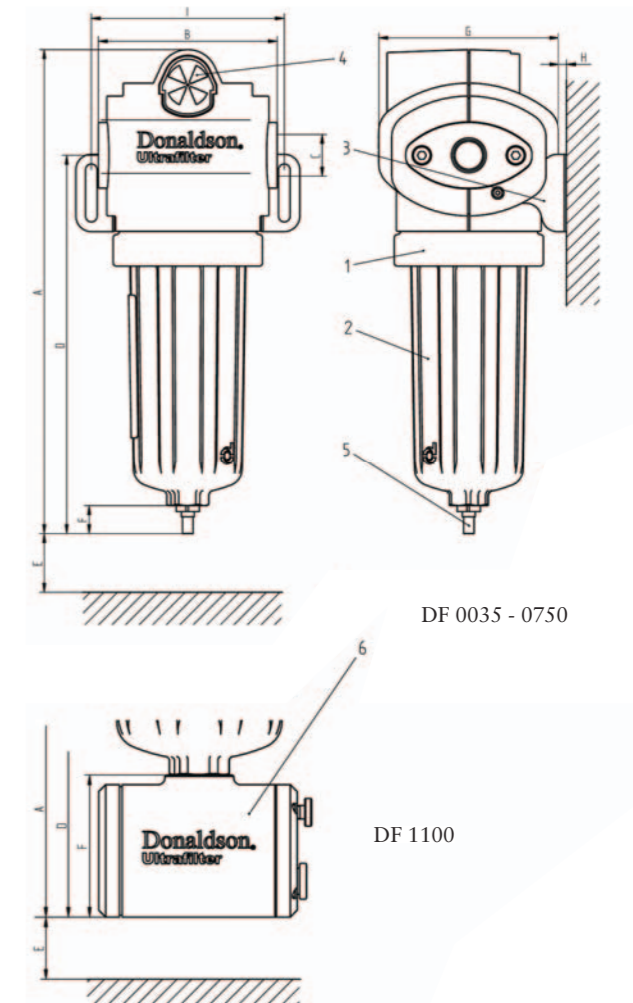

Materials	
Filter housing	Aluminium die cast
Econometer	Polymer
Float drain	Polymer / aluminium mold cast
Sealings	Viton

Max. operating pressure	16 bar
Test pressure	22.9 bar
Perm. operating temperature	+1°C / +65°C

Size housing / element	Flow rate* m3/h	Volume (l)	Weight** (kg)	A mm	B mm	C	D mm	E mm	F mm	G mm	H min/max mm	I mm
0035	0035	0.20	0.5	254	76	G 3/4	186	100	27	85	5	84
0070	0070	0.40	0.9	297	103	G 1	222	115	27	107	5 / 34	107
0120	0120	0.50	1.0	341	103	G 1 1/2	266	150	27	107	5 / 34	107
0210	0210	1.15	2.0	382	139	G 2	300	180	27	140	5 / 53	150
0320	0320	1.50	2.2	442	139	G 2 1/2	360	250	27	140	5 / 53	150
0450	0450	5	5.2	586	190	G 3	487	250	27	203	5 / 73	190
0600	0600	5	5.2	586	190	G 3 1/2	487	250	27	203	5 / 73	190
0750	0750	5	5.2	586	190	G 4	487	250	27	203	5 / 73	190
1100	1100	6	7.2	764	190	G 4 1/2	665	250	103	203	5 / 73	190

\* Nominal flow at 7 bar g, m3/h related to 1 bar abs. and 20°C  
\*\* without filter element

Operating Pressure (bar g)	1	2	3	4	5	6	7	8	9	10	11	12	13	14	15	16
Conversion Factor (fp)	0.25	0.38	0.50	0.63	0.75	0.88	1.00	1.13	1.25	1.38	1.50	1.63	1.75	1.88	2.00	2.13

Ultra-Filter DF - **S** **0035** **Z** **U**

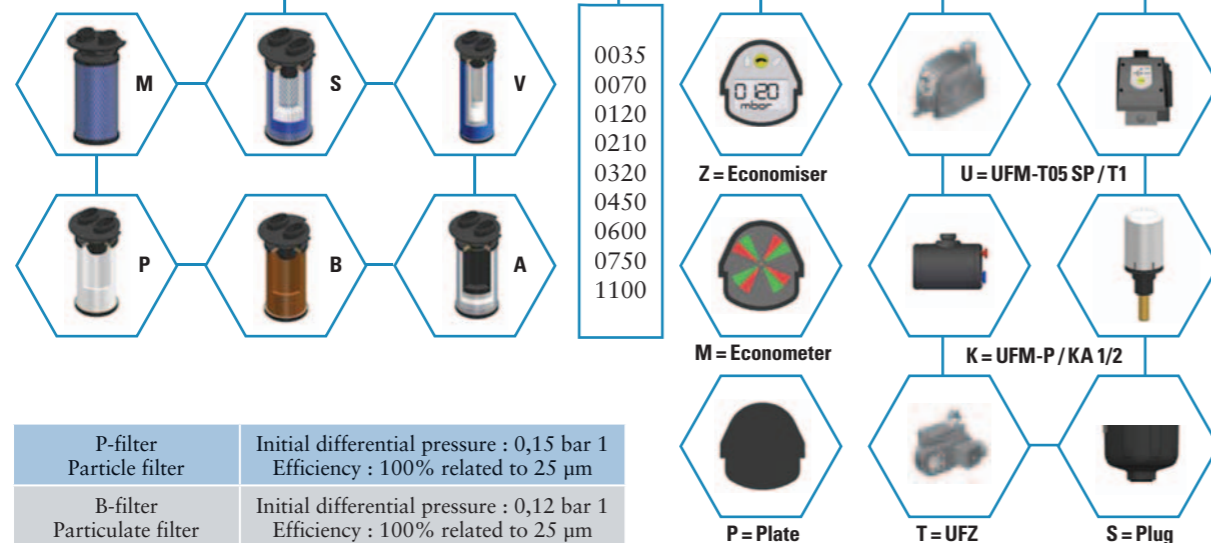

P-filter Particle filter	Initial differential pressure : 0,15 bar 1 Efficiency : 100% related to 25 µm
B-filter Particulate filter	Initial differential pressure : 0,12 bar 1 Efficiency : 100% related to 25 µm
A-filter Activated carbon filter	Initial differential pressure : 0,15 bar 1 Residual oil content : 0,003 mg/m³ 3
V-filter Coalescing filter	Initial differential pressure : 0,11 bar 1 Residual oil content: < 0,2 mg/m³ 2
M-filter Coalescing filter	Initial differential pressure : 0,11 bar 1 Residual oil content : < 0,02 mg/m³ 2
S-filter Coalescing filter	Initial differential pressure : 0,13 bar 1 Residual oil content : < 0,01 mg/m³ 2

1 related to nominal performance at 7 bar, dry condition  
2 related to a inlet concentration of 3 mg/m³  
3 when upstream connected a M- or S-filter